

### Sync Pulse Generator and Test Signal Generator

#### 9400 SPG/TSG - Reliable and Easy-To-Use

The 9400 3G/HD/SD Sync Generator and Test Signal Generator is a stable timing source that is perfect for local reference generation in broadcast, remote trucks and post. HD SDI, SD SDI, analog composite, HD Tri-Level Sync, timecode, AES audio and analog audio reference outputs are generated.

The 9400 can operate from an internal precision frequency reference as a stand alone Master Sync Generator or lock to a video reference or 10 MHz precision reference. Alternately, the 7400-GPS option can be used.

The 9400 can output multiple formats of tri-level sync, 3 Gb/s and 1.5 Gb/s HD SDI test signals, SD composite and SDI test signals, and color black reference. The 9400 can simultaneously deliver both 525 (NTSC) and 625 (PAL) based signals. Color framing tracks the reference signal. All of the video outputs are derived from the same time base and can be timed with respect to each other. The 9400 has two identical generators, Generator A and Generator B, each with a variety of outputs. Each set of outputs can be timed with respect to the reference to any point in the television frame. All of the Outputs from a particular Generator must be selected within the same frame rate family.

The Avenue Frame features a retainer bar to ensure that modules remain properly seated even in the most demanding mobile environments.

#### Favorite Test Patterns

There are over 30 test signals including: Full and Split Field Bars at 75% and 100% with Pluge; Black; Flat Field; Pulse and Window; Ramp; Crosshatch; Safe Title; Blanking Markers; Cosite; Checkfield, Pathogenic, and 5 Step. The Cyclops feature adds a motion element to the selected video test signal to assist in locating a signal that might be frozen in a frame sync somewhere in the signal chain. An ID slate with user programmable text can overlay the test pattern.

#### Customizable Test Patterns

In addition to the standard suite of test patterns, users can create custom test patterns on a computer. Simply transfer test patterns to the included Secure Digital flash memory card using Avenue Logo software and a standard card reader, then insert the memory card into the 9400. Test patterns can include motion and an associated audio clip.

#### Audio Generators

The 9400 provides extensive support for analog and digital audio. Because all of the video outputs can be locked to a common time base, the AES digital audio outputs are always synchronous with all of the video outputs – regardless of format. Multiple tone generators make it easy to identify multi-channel content. With the 9400-EX Expando option, an AES input is provided which can be fed by a multi-channel encoded bitstream. This bitstream will be included in the set of signals that can be embedded into the test signal outputs.

The audio section of each generator supports sixteen audio channels. The content of each channel is independently programmable. Choices include adjustable frequency tone

generators, tone sweeps, Silence, Timecode, Audio Clip playback from Secure Digital Card, and the external AES input. Left/Right Channel ID that synchronizes to the Cyclops feature can also be selected.

All sixteen of these channels can be embedded in the SDI outputs. Each AES output can select from any of the 8 pairs that make up these 16 channels. Similarly, the stereo analog output of each generator can be driven from any of these audio signal pairs.

#### Multiple Timecode Generators

Multiple time code generators make the 9400 convenient for post applications. Timecode is delivered as LTC (both 75 Ohm BNC and 110 Ohm Balanced), VITC, and DVITC. One generator can be configured to produce 525/59.94 drop frame timecode while the other generator is making 1080i/23.98.

#### 9400-EX Expando Module for Total Flexibility

If your facility seems to need every type of reference signal on earth, the 9400 module with the 9400-EX is just what you need. Two generators provide myriad reference signals including: 12 types of 3 Gb/s or 1.5 Gb/s HD SDI black and bars, SD SDI bars and black, composite bars and black, HD Tri-Level Sync, Word clock, AES and analog audio tone, and LTC. The two generators can be independent or one generator can be locked to the other. The control system lets you assign signal types to the 17 output BNCs and 2 high-density D connectors. The 9400-EX option can be installed in the field.

#### 7400-GPS Option for the Ultimate Precision Reference

For the ultimate in precision, the 7400-GPS option can be used with the 9400 module. The purpose of this GPS option is to provide an extremely precise frequency reference. The oscillator on the 7400-GPS is more accurate than a typical internal precision standard and is equivalent in accuracy to an atomic standard. Increased frequency accuracy makes it possible to frame synchronize signals between different facilities with virtually no dropped or doubled frames. The GPS option also provides precise time of day information, which can be used to drive the 9400 module's internal timecode generators.

The 7400-GPS option seamlessly integrates into the Avenue system by plugging directly onto the 9400 module. It can be easily installed in the field. The 7400-GPS option consists of a compact, weatherproof antenna (with internal high-gain pre-amp) and a receiver sub module which mounts directly to the 9400 module. The included GPS antenna mounts onto standard 3/4" threaded pipe, metal or plastic. Connection from the F-style coaxial fitting on the antenna to the appropriate BNC on the Avenue Frame can be made with customer supplied standard 75 ohm cable. The coax cable can be routed through the center of the pipe for a completely waterproof installation. When low loss cable such as Belden 1694A is used, the antenna can be placed up to 200 feet (60 meters) from the frame. Ideally, the antenna is mounted outdoors where it has an unobstructed view of the sky.

## A Complete SPG and TSG System

The 9400 can be combined with other Avenue modules to create a complete sync pulse and test signal chain. The 7410 is a four channel HD Tri-Level Sync generator that can output four different types of Tri-Level Sync simultaneously and is very useful in post and hybrid facilities. When additional composite black is needed, the 5405 can be used to provide two independent pairs of composite outputs. The 5150 distribution amplifier can be used to distribute multiple copies of AES audio, Tri-Level Sync or composite black signals as needed. For 3 Gb/s or 1.5 Gb/s HD test signal and black distribution, the 9125 DA is a good fit.

### Configuration Example

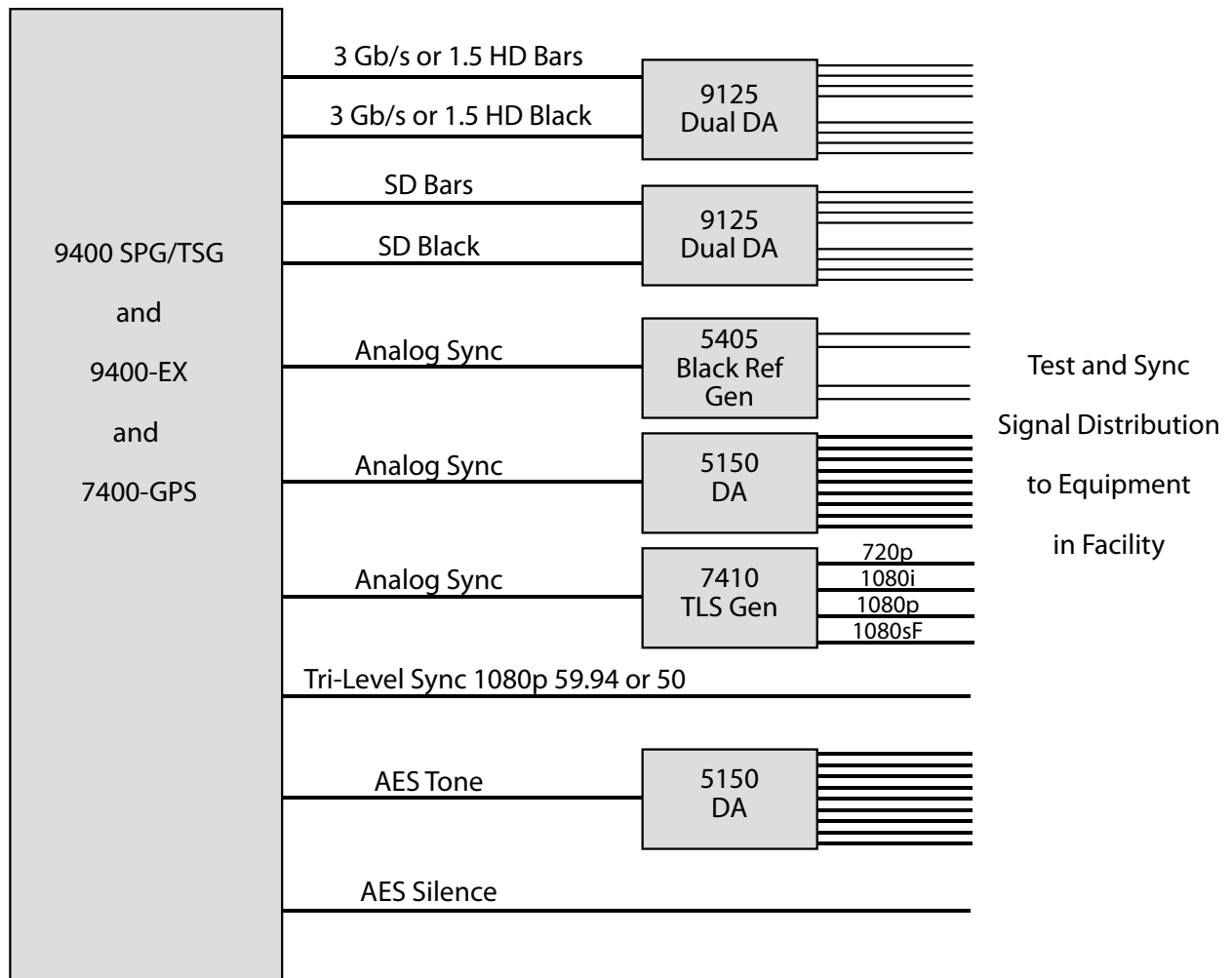

### Features

- » Use as Master Sync Gen or lock to external reference or GPS
- » Can output SD SDI, 1.5 Gb/s HD SDI, 3 Gb/s HD SDI, composite timecode and audio simultaneously
- » Outputs can be independently timed
- » Generates 30+ test signals
- » Flash memory card for making custom test patterns

## Description of Outputs

**Generator A**

**SDI Out A** – Outputs 3 Gb/s or 1.5 Gb/s HD or SD test signals. Select frame rate family for all of Generator A; 59.94, 50 or 60. Output can include 16 channels of embedded audio – tone, silence, external audio, or audio file. Can also include DVITC.

**Programmable Out 1A** – Outputs analog composite video (Bars, Black, or Test if Out A is SD), Tri-Level Sync Gen #1. Composite output can include VITC.

**Programmable Out 2A** – Outputs one of the following: Tri-Level Sync Gen #2, LTC, AES (any of 8 pairs), AES silence, Word clock, 6 Hz pulse, 10 Mhz (only if locked to internal or GPS reference).

**Programmable Out 3A** – Outputs one of the following: Tri-Level Sync Gen #2, LTC, AES (any of 8 pairs), AES silence, Word clock, 6 Hz pulse, 10 Mhz.

**Analog Audio** – stereo output, 1 of 8 pairs from the audio generator.

When the 7400-EX option is installed, the following additional outputs are available for **Generator A**

**Cpst Black Out A** – Outputs composite black, 525 or 625 as per the selected frame family for the Generator. Can include VITC. Independently timeable.

**SDI Black Out A** – Outputs digital black in the same standard and frame family as test signal SDI Out A – SD, HD 1.5 Gb/s or HD 3 Gb/s. Up to sixteen channels of embedded audio. Can include DVITC.

**Programmable Out 4A** – Outputs one of the following: Tri-Level Sync Gen #3, LTC, AES (any of 8 pairs), AES silence, Word clock, 6 Hz pulse, 10 Mhz.

**Programmable Out 5A** – Outputs one of the following: Tri-Level Sync Gen #3, LTC, AES (any of 8 pairs), AES silence, Word clock, 6 Hz pulse, 10 Mhz.

**Programmable Out 6A** – Outputs one of the following: Tri-Level Sync Gen #3, LTC, AES (any of 8 pairs), AES silence, Word clock, 6 Hz pulse, 10 Mhz.

**Expanded Analog Audio** – provides an additional stereo output, 1 of 8 pairs from the audio generator.

**Generator B**

Has the same outputs as noted for Generator A. Generator B is completely independent from Generator A. Generator B can operate in a different frame rate family and its set of outputs can be timed independently.

Broadcast Application Configuration Example

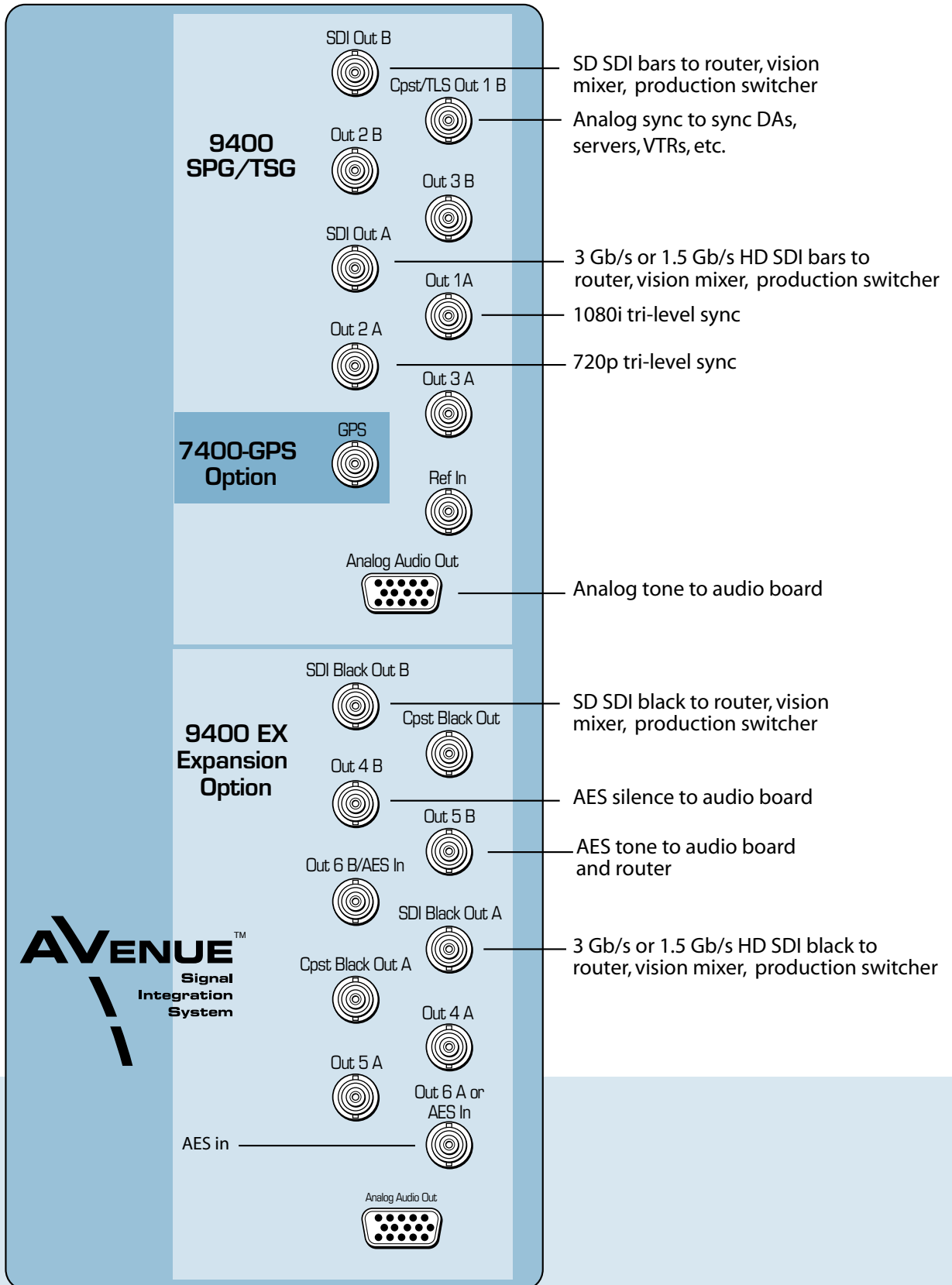

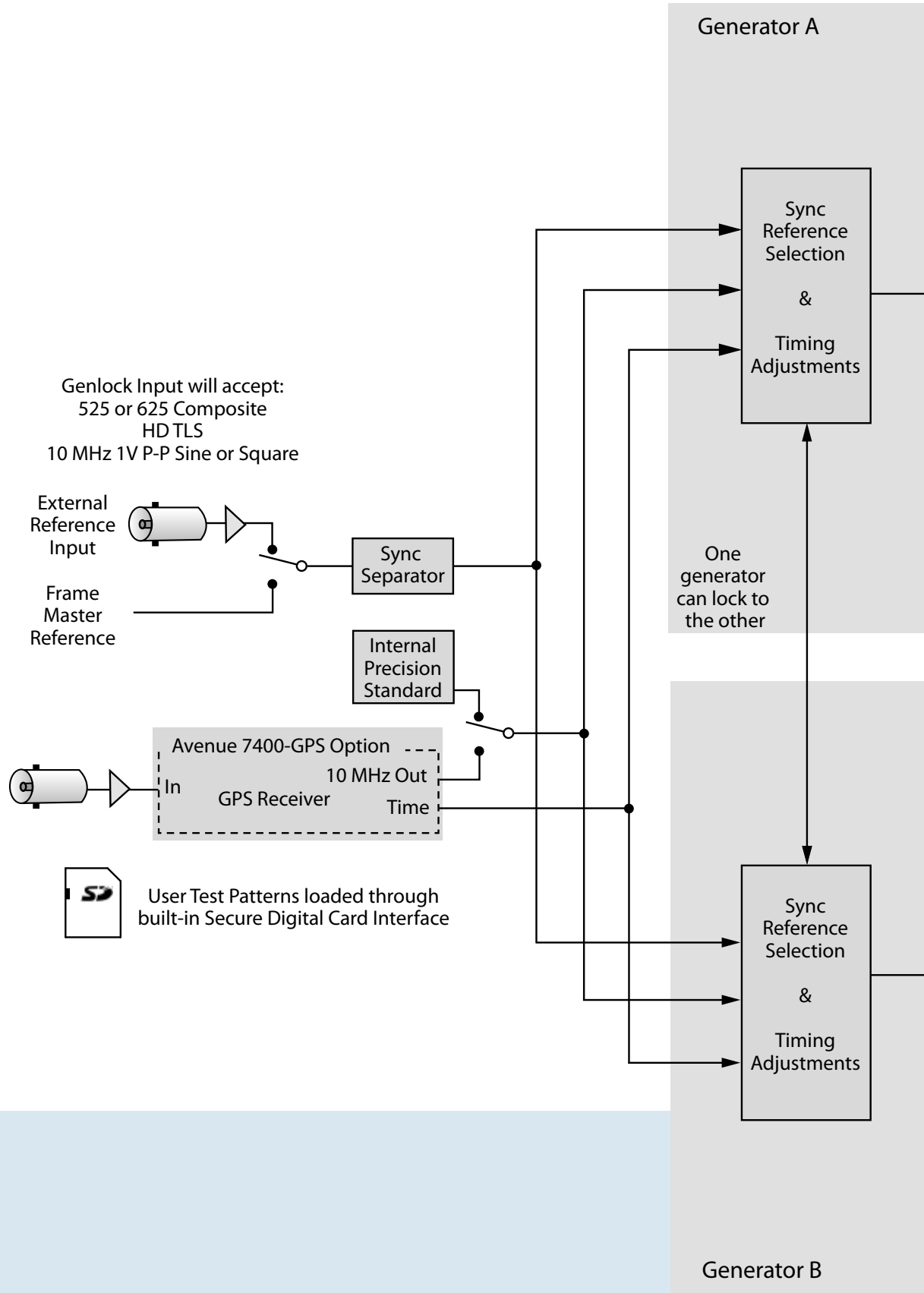

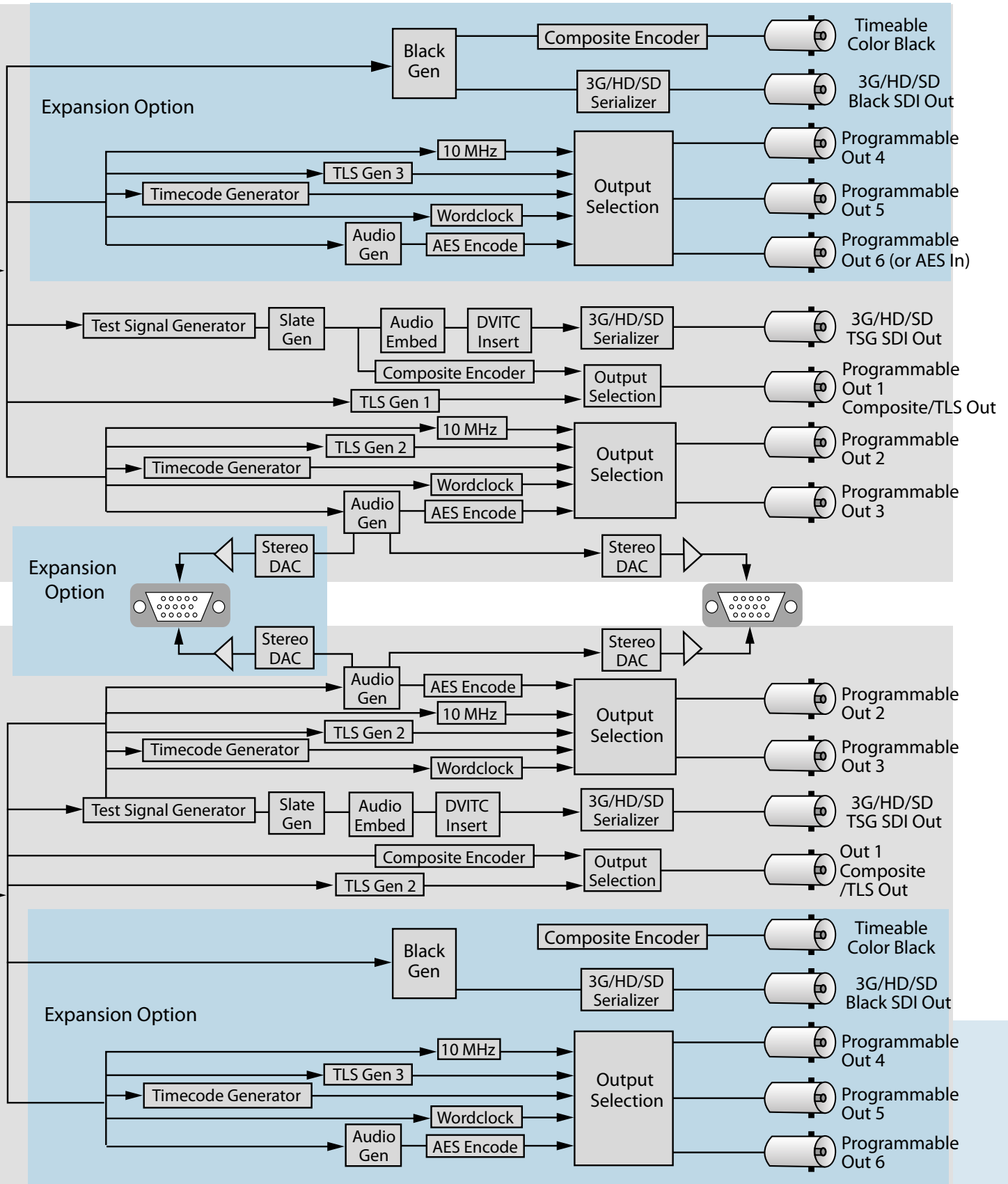

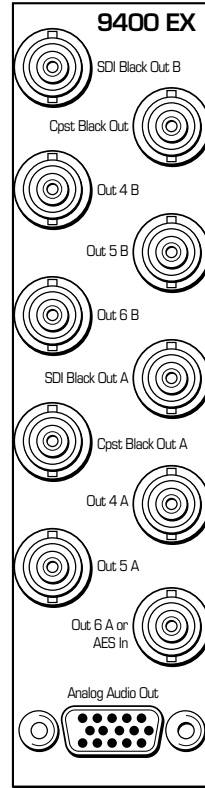
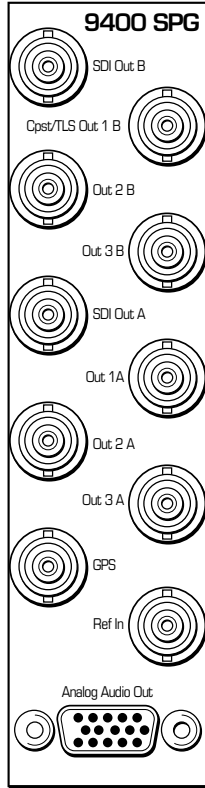
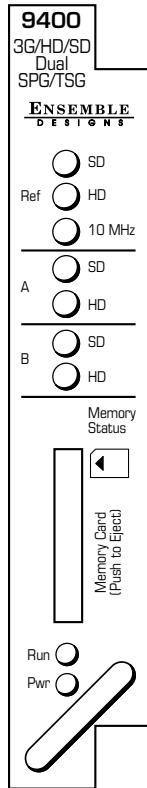

**Order Info:**

**9400**

SPG/TSG Module (Takes up one slot in Avenue frame)

**9400-EX**

Expansion module to be used in conjunction with 9400 (Takes up one slot in Avenue frame)

**7400-GPS**

GPS receiver option that plugs onto 9400 module. (Does not take up a slot in Avenue frame)

Includes weatherproof antenna. Antenna mounts onto standard 3/4" pipe. Customer to provide 75 Ω 1694A coax up to 60 m/200 ft with F connector for antenna connection and BNC for Avenue frame connection.

### Standards Supported

1080i (SMPTE 274M -4,5,6) 50, 59.94 or 60 Hz  
720p (SMPTE 296M -1,2,3) 50, 59.94 or 60 Hz  
1080p (SMPTE 274M -9,10,11) 23.98, 24, 25 Hz  
1080sF (RP211 -14,15,16) 23.98, 24, 25 Hz  
3 Gb/s Level A or Level B (SMPTE 424M, 425M)  
625i 50  
525i 59.94  
Composite PAL, NTSC

### Frame Rate Families

Each 9400 has 2 identical Generators, each with a variety of outputs. All of the outputs from a particular Generator must be selected within the same frame rate family.

50 Hz (625) Derived Family: 1080i/50, 720p/50, 1080p/25, 1080sF/25, 625i/50  
59.94 Hz (525) Derived Family: 1080i/59.94, 720p/59.94, 1080p/23.98, 1080sF/23.98, 525i/59.94  
60 Hz Derived Family: 1080i/60, 720p/60, 1080p/24, 1080sF/24

### Reference Input

Number	Two: External or Frame Master Reference
Signal Type	PAL or NTSC composite video or HD Tri-Level Sync or 10 MHz 1V P-P sine or square
Return Loss	>40 dB (applies to external ref input)

### Serial Digital Outputs

Type	HD Serial Digital 1.485 Gb/s SMPTE 274M, 292M or 296M HD Serial Digital 2.97 Gb/s SMPTE 424M, 425M or SD Serial Digital 270 Mb/s SMPTE 259M
Impedance	75 Ω
Return Loss	>15 dB to 1.485 GHz
Max Cable Length	270 Mb/s 300 meters 1.485 Gb/s 100 meters 2.97 Gb/s 70 meters Belden 1694A

### Tri-Level Sync Outputs

Signal Type	HD Tri-Level Sync
Output DC	±50 mV
Return Loss	>30 dB to 30 MHz

### Composite Outputs

Signal Type	NTSC / PAL
Impedance	75 Ω
Return Loss	>40 dB DC to 5.5 MHz
Frequency Response	±0.1 dB 0 to 5.0 MHz
Output DC	±50 mV
K Factor	<1.0%
Differential Phase	<1.0 degree
SCH Phase	±2 degrees
Delay	adjustable over full frame in sub degree steps
Color Framing	tracks ref

### Accuracy

Internal Reference (TCXO)	
Freq Error	<10 <sup>-7</sup> < ±1 Hz F <sub>sc</sub>
GPS Option	
Freq Error	<10 <sup>-12</sup>

### Stability

Analog Jitter	<1 ns
Digital Jitter	<0.2 UI (0.13 UI typical)
AES Jitter	<1 ns

### AES Audio Outputs

Type	AES3id tone, 50 Hz to 20 KHz, or silent
Resolution	24 bit

### Analog Audio Outputs

Number	Two stereo pairs or four mono
Type	tone, 50 Hz to 20 KHz, or silent
Impedance	30 Ω, balanced
Reference Level	-10 to +4 dBu, selectable

### Additional Output Choices

Timecode	DVITC on the SDI outputs VITC on the composite outputs LTC on BNC unbalanced or on HD-15 balanced, 1 V P-P drop or non-drop for NTSC
6 Hz Pulse Word Clock 10 MHz	when locked to internal or GPS reference

### Flash Memory

Number	One
Type	Secure Digital SD Flash Memory Card
Size	1 GB card included

### File Type

Video	.tga
Audio	.wav, .mp3, .wma

### General Specifications

Power Consumption	10 watts for 900 10 watts for 9400-EX
Temperature Range	0 to 40°C ambient (all specs met)
Relative Humidity	0 to 95%, noncondensing
Altitude	0 to 10,000 ft