

### Video Processing Frame Synchronizer

The story of the 8500 Video Processing Frame Synchronizer begins with flexibility. This new Avenue module packs more features into a single card slot than anything we've ever offered before.

#### Total Flexibility

The flexible architecture of the 8500 makes it a multipurpose, "Do Anything," module. Uncompromising attention to image quality and fidelity means that it can do all of these things very well.

With both SD SDI and 12 bit analog inputs (composite, component, or S-Video [Y/C] formats), the 8500 is ready to take on any signal acquisition challenge. And you can deliver that signal simultaneously in both SDI digital component and 12 bit analog composite. In between those inputs and outputs lie a rugged frame synchronizer, and a powerful proc amp. An infinitely adjustable timing system genlocks to your house reference. A choice of an optional audio processor with analog and digital I/O, and an optional Digital Noise Reducer round out the 8500 Series — it's the total solution to signal acquisition and handling. No matter what sources you have — now, or in the future — the 8500 is ready.

#### Uncompromised Pictures

Whether your input is standard definition SDI Digital Component, Analog Composite or Analog Component, the 8500 handles it with precision and accuracy. The SDI input is carried at full uncompressed bandwidth throughout the entire module, and EDH monitoring of the digital input alerts you to any incoming problem. Analog inputs are 4x oversampled at 12 bits of resolution. Composite signals are decoded using an adaptive comb filter. Complete control over signal levels is provided.

#### Rock Steady TBC/Frame Synchronizer

Input video is synchronized to your house reference by an agile TBC/Frame Synchronizer. Even noisy and jittery analog sources are faithfully tracked to provide a steady, genlocked output. Robust signal handling ensures proper time base correction for virtually any source, even a consumer VHS machine. Select the SDI input and the 8500 is a serial digital frame sync.

#### Complete Proc Amp Functions

The 8500 has a full-featured Proc Amp for adjustment of every signal parameter. Proc controls include Video and Chroma Gain, NTSC-style hue rotation, Black Balance, and pedestal. Black and White clips can be set to prevent excessive signal excursions.

A Detail Enhancer recovers information that has been lost due to poor frequency response in upstream systems. Certain values represented in serial digital component may be illegal in the PAL or NTSC composite domains. The Predictive Composite Clipper mode identifies picture elements that would be illegal in analog composite, and limits color saturation and luminance excursions. You can be confident that the work you're doing in digital component will look its best in composite.

Selective (toothed) vertical blanking lets you choose to pass or strip content in the vertical interval on a line-by-line and field-by-field basis. To help optimize the settings in the Proc Amp, a Split Screen mode allows you to compare the processed output with the original material.

#### Digital and Analog Outputs

The 8500 has simultaneous SDI and analog composite outputs. They are fully timed to your house reference, including the subcarrier and Sch phase of the composite output. The analog output is constructed at 8 x oversampling with 12 bits of quantizing resolution.

This output flexibility of the 8500 makes it easy to handle the digital transition in an existing analog facility. Both digital and analog destinations can be fed from the same source module. On loss of input, the output can mute to black or freeze on the last good frame of video.

#### Total Control

Because the 8500 is an Avenue module, every function and parameter can be controlled from the Avenue control system. Memory registers can be used to save the complete configuration of the module, making it easy to change instantly between different configurations. Any combination of Express Panels, Touch Screens and PCs can be used to control the 8500. The Express Panel is especially well suited for use with the 8500.

#### Channel Density

Ten 8500 Video Processors (including both the Audio and DNR Options) can be accommodated by the Avenue 3RU Frame. Now that's an efficient use of real estate!

#### Features

- » 12 bit composite, component and S-Video analog video input
- » 4x oversampled analog input
- » SD SDI (Serial Digital) input
- » Adaptive Comb Filter decoder
- » Automatic 525/625 switching
- » A to D, and D to A, all in one module
- » Full-featured TBC/Frame Synchronizer
- » Excellent tracking of noisy inputs
- » Comprehensive Proc Amp controls

- » Predictive Composite Clipper
- » Video Legalizer
- » Sharpness Filter
- » Black and White clips
- » Line-Selectable toothed blanking
- » Split Screen mode
- » External genlock reference input
- » EDH detection and insertion
- » Simultaneous SD SDI and analog composite outputs
- » 12 bit, 8x Oversampled analog output
- » Outputs are fully timeable
- » Internal color bar generator
- » Total control through the Avenue control system
- » Memory Registers
- » Compatible with the full Avenue line
- » 10 complete channels in just 3RU
- » Accepts the 8410, 8415, or 8510 Audio Processor options
- » 4- or 8-channel audio options
- » Accepts the 8520 Digital Noise Reducer option
- » Audio Automatic Gain Control option

**Analog Inputs**

Signal Type	SMPTE Y, Pr, Pb Beta Y, Pr, Pb NTSC, PAL Composite NTSC, PAL S-Video (Y/C)
Impedance	75 $\Omega$
Return Loss	>40 dB
Input DC	$\pm 1$ volt DC
Input Hum	<100 mV

**Serial Digital Input**

Signal Type	ITU-R 601, SMPTE 259M-C
EDH	Fully compliant
Impedance	75 $\Omega$
Return Loss	>15 dB
Max Cable Length	300 meters Belden 1694A
Automatic Cable Input Equalization	

**Reference Input**

Number	One external One internal Master Timing Ref
Signal Type	1 V P-P Composite Video PAL or NTSC
Impedance	75 $\Omega$ , BNC
Return Loss	>40 dB

**Analog to SDI Performance**

Bit Resolution	12 bit input quantization 4 x oversampling
Signal to Noise	>62 dB, weighted
Frequency Response	
Composite & Y	$\pm 0.1$ dB, 0 to 5.5 MHz
Cr, Cb	$\pm 0.1$ dB, 0 to 2.75 MHz
Minimum Delay	90 $\mu$ sec

**SDI to SDI Performance**

Passes entire SDI signal from input to output, including embedded audio and all other ancillary data

**Analog Output**

Signal Type	PAL or NTSC Composite Standard follows input
Impedance	75 $\Omega$
Return Loss	>40 dB
Output DC	<50 mV

**Serial Digital Outputs**

Number	One, two or four (selectable)
Signal Type	SMPTE 259M-C
EDH	Fully compliant
Impedance	75 $\Omega$
Return Loss	>15 dB
Output DC	None (AC coupled)

**SDI to Analog Performance**

Bit Resolution	12 bit output reconstruction 8 x oversampling
Signal to Noise	>65 dB
Frequency Response	$\pm 0.1$ dB, 0 to 5.5 MHz
K Factor	<1%
Sch Phase Error	< $\pm 2$ degrees
Differential Phase	<1 degree
Differential Gain	<1%
Color Field Sequence	Locked to selected Ref
Minimum Delay	25 $\mu$ sec

**General Specifications**

Power Consumption	10 watts (with 2 options installed)
Temperature	0 to 40°C ambient (all specifications met)
Relative Humidity	0 to 95%, noncondensing
Size	Standard Avenue Module Occupies one slot in 3RU or 1RU Frame (including 1 audio and DNR sub module)

# Avenue 8500 Video and Audio Processor

## Features

- » SD Analog and Digital Inputs
- » SD Analog and Digital Outputs
- » TBC/Frame Sync
- » Legalizer
- » Digital Proc Amp
- » Digital Noise Reducer option
- » Passes embedded audio
- » Embedded Audio Processing option
- » 4 or 8 channels
- » Tracking Audio Delay

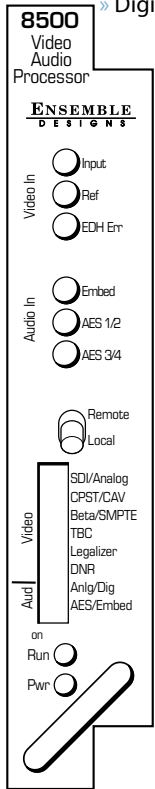

### Input Flexibility

Composite and S-Video  
Component  
SD SDI

### Image Quality

12 Bit Analog to Digital Conversion  
4x Oversampling

## 8500 Video Processor Module

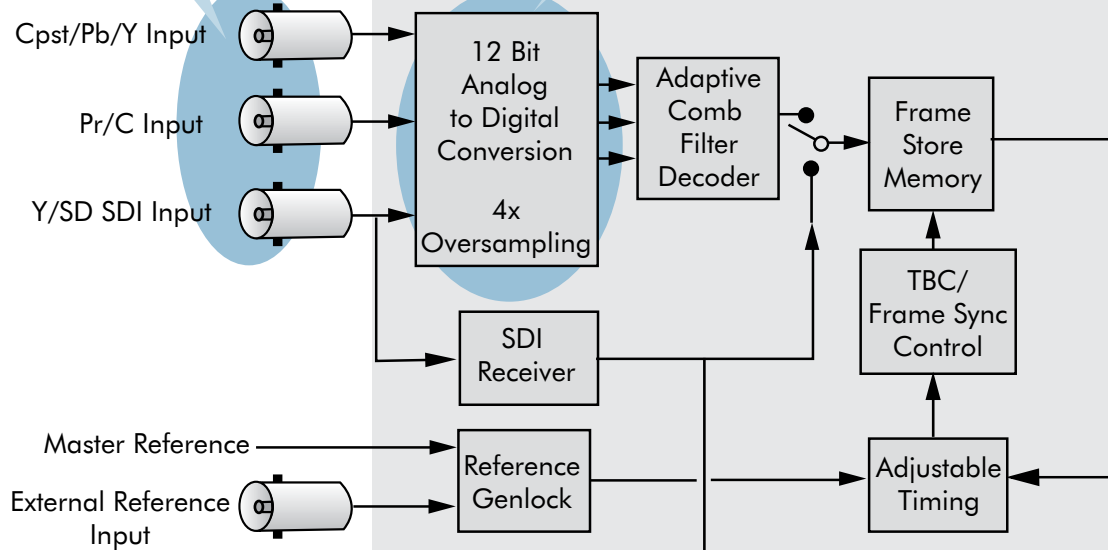

## 8510 Audio Processor Option

### 4 or 8 Channels

Sub module  
Choices for 4 or 8  
Channel Processing

AES Input CH 1/2

AES Input CH 3/4

Analog Audio I/O

Audio Disembed

Source Selection  
Level Adjust  
Swap & Shuffle  
Channel Mixing

4 Channel  
24 Bit  
ADC

### Analog Flexibility

User Configurable as:  
4 Balanced Inputs  
4 Balanced Outputs  
or 2 Inputs and 2 Outputs

### Sound Quality

24 Bit Conversion and Processing  
for Fidelity and Accuracy

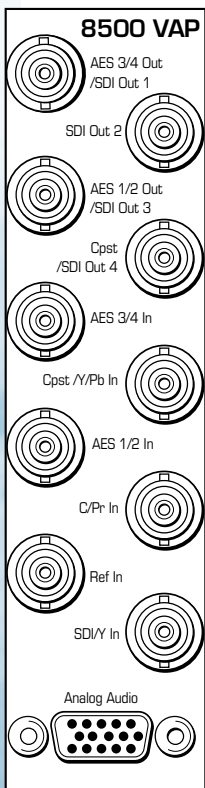

**8520 DNR Option**

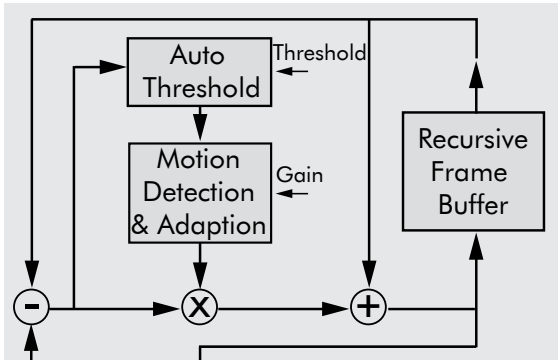

**Image Quality**

MPEG Preprocessing  
Image Cleanup

**Output Flexibility**

Simultaneous Digital  
and Analog Outputs

**Video Processing Amplifier**

- Gains
- Pedestal
- Hue
- Detail
- Legalizer
- White Clip
- Black Clip
- Chroma Clip
- Selective Blanking
- Black Balance

Serializer

12 Bit D to A & Encoder

**Timed Outputs**

Fully Timed Outputs  
Composite Out is ScH Phased

Module Control  
μProc

**Avenue  
Control  
System**



**Express Panel**

Adjust Any Parameter  
Dedicated Knobs for  
Proc Adjustments

**Digital  
Signal Processing**

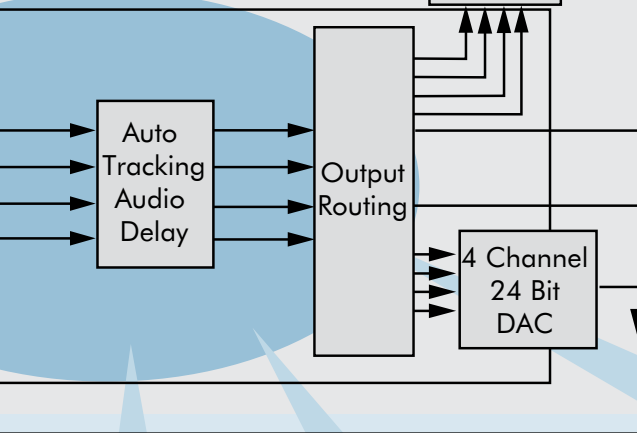

**Input Flexibility**

Balanced Analog  
Digital AES  
Embedded Inputs

**Audio Horsepower**

Control All Levels  
Mix, Swap and Shuffle  
any input to any output

**Perfect Lip Sync**

Automatically Tracks the Delay  
imposed by Video Frame Sync

SD SDI or  
AES 1/2 Out

SD SDI or  
AES 3/4 Out