

HD Up /Down /Cross Converter

Do It All With One Module

The 7900 is a flexible, configurable Up and Downconverter for use in broadcast and post. It can process SD (Standard Definition) signals into HD, downconvert HD signals into standard definition, and perform Format and Aspect Ratio Conversion on both SD and HD signals. The 7900 and one of the optional audio sub modules together only occupy one slot in an Avenue frame – now that's efficient use of space.

It's Smart – No Need for Configuration

The 7900 can be configured to continually output your facility's preferred HD format. Just connect any HD or SD signal to the input and the 7900 will convert it to the appropriate format for output. And, if the 8415 audio option is installed, the audio will have automatic delay compensation.

Upconversion

When configured as an upconverter, the 7900 has a standard definition SDI input and four HD SDI outputs. Excellent for on-air use, the 7900 is equally at home in an HD island, in a signal ingest installation, or in a production application.

The 7900 uses sophisticated Edge and Motion Adaptive Noise Reduction, ensuring delivery of a pristine output that is excellent for use in broadcast. All processing is performed on progressive signals at full bandwidth 4:4:4, for optimum signal quality. Signals are interlaced and deinterlaced as required with motion adaptation and edge interpolation. Aspect ratio conversion choices include: Letterbox, Anamorphic, Crop and Zoom.

Input standard and frame rate are auto-detected. The 7900 automatically performs 16 bit SD and HD color space conversion. The built-in Proc Amp provides adjustment of signal parameters with controls for Video, Chroma, Setup and Hue. Vertical interval data is faithfully preserved and is passed from SD to HD. The upconverted output is timeable with respect to the reference input.

Downconversion

When used as a downconverter, the 7900 has an HD SDI input and four outputs that can be configured as two SDI and two composite outputs, or four SDI outputs. Whether it's providing digital feeds to production switchers and routers, or analog monitoring – the 7900 handles it all.

The downconversion process includes Picture Detail Enhancement and Anti-Alias Filtering, which makes for a pristine SD output. The Aspect Ratio Conversion process offers Resizing and Repositioning with choices for: Letterbox, Anamorphic, Crop and Zoom. The 7900 automatically adjusts between HD and SD color space and gamma. Proc amp controls are provided in the form of Video, Chroma, Setup and Hue.

Both the digital and analog outputs are timeable with respect to the reference input. Composite outputs can be timed into house with proper subcarrier and Sch phase.

Cross Conversion

The 7900 provides cross conversion between HD 1.5 Gb/s formats, processing all popular variations of 1080 and 720, making it simple for every facility to ingest any type of HD signal.

All popular variations of 720p, 1080i, 1080sF and 1080p are supported. The 7900 converts between any HD signals within the 59.94/23.98/29.97 family, within the 50/25 fps family, or within the 60/30 fps family. 3:2 pulldown is used when converting between 59.94 and 23.98. Film mode is automatically detected.

Metadata

HD closed captioning is carried in data packets in the vertical interval ancillary data space. The 7900 properly translates between HD caption data and traditional SD captioning (line 21 or 23) so that closed captioning content is converted transparently between video standards and formats.

Automatic Aspect Ratio Conversion

The 7900 supports WSS (Wide Screen Signaling), and AFD (Active Format Description) and other methods used to mark or identify the aspect ratio of the video content. These flags are generated at the output of the module, and they are read at the input. This allows the up and downconversion process to adapt automatically to material that is already in letter or pillarbox form in order to produce the most appropriate conversion.

Audio Options

When an audio sub module is installed, audio is automatically delayed as needed to compensate for the video processing in the 7900. For complete audio processing, choose from three different audio sub modules. Sub modules plug onto the 7900 board and do not take up a slot in the frame.

The 8415 is an eight-channel audio sub module with AES I/O that provides management of embedded audio in the processing path, or supports audio embedding/disembedding alongside the video processing elements. Embedded audio is safely bypassed around the video frame store with the lip sync preserved. Level adjustments and channel shuffling are accessed through the built-in audio mixer. The 9670 Automatic Gain Control option can be added to the 8415. All audio processing is performed at full 24 bit resolution.

The 7610 provides carriage of up to eight channels of embedded audio through the format conversion process. Embedded audio in the input signal is delayed to match the video delay and preserve lip sync. The delayed content is reinserted in the video output. No level adjustment or channel swapping is provided.

In addition, the 7615 provides processing for signals with eight channels of embedded audio. It offers the same processing and AES I/O as the 8415 plus the ability to decode Dolby E signals.

Complete Control System

The 7900 can be configured locally or controlled and configured remotely with Avenue Touch Screens, Express Panels, or Avenue PC Software. Alarm generation, configurable user levels, module lock out, and customizable menus are just some of the tools included in the Avenue Control System.

Features

- » Upconverter
- » Downconverter
- » Crossconverter
- » Aspect Ratio Converter
- » Smart auto-config – set output, then feed any input
- » Proc Amp and Frame Sync

- » Audio Mux/Demux optional
- » Audio Automatic Gain Control optional
- » Add audio sub module option for delay and processing

- » All processing performed on 4:4:4 progressive signals
- » Accepts asynchronous signals
- » Reference input – output is timeable
- » Automatically adjusts between SD/HD color space and gamma
- » 16 bit processing
- » Edge and Motion Adaptive Noise Reduction
- » Picture Detail Enhancement
- » Anti-Alias Filter
- » Passes closed captioning
- » Auto detection of input standard and frame rate
- » 3:2 pulldown

- » Built-in test pattern and tone
- » Local and remote control
- » Occupies one slot in frame, even with audio option

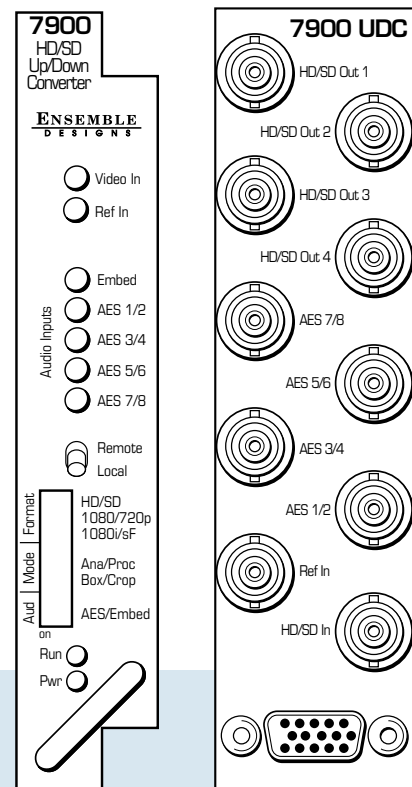

Conversion Directions

Up/Down Conversion between

525 (NTSC) and 1080i/59.94, 720p/59.94, 1080p/23.98,
1080sF/23.98
625 (PAL) and 1080i/50, 720p/50, 1080p/25, 1080sF/25

Cross Conversion within frame rate families

525 Derived Family: 1080i/59.94, 720p/59.94,
1080p/23.98, and 1080sF/23.98
625 Derived Family: 1080i/50, 720p/50,
1080p/25, 1080sF/25

AES/EBU Digital Inputs (with 8415 sub module option)

Number	Four (total of 8 channels)
Signal Type	AES3id
Connectorization	Coaxial, 75 Ω
Bit Depth	20 and 24 bit
Sample Rate	30 kHz to 100 kHz (sample rate converted internally to 48 kHz)
Crosstalk	<144 dB
Dynamic Range	>144 dB
Reference Level	-18 or -20 dBFS (selectable)
AC-3, Dolby E	Supported when inputs are synchronous

Embedded Inputs

Number	Four AES Streams (from video input) Eight channels from any two of four groups Selectable to any of four groups
Channels	Eight
Bit Depth	20 and 24 bit

AES/EBU Digital Outputs

Number	Four (total of eight channels)
Signal Type	AES3id
Connectorization	Coaxial, 75 Ω
Bit Depth	20 and 24 bit
Sample Rate	48 kHz
Reference Level	Synchronous to video output -18 or -20 dBFS (selectable)

Embedded Output

Number	Four or two depending on configuration
Group Assign	Cascade, or Replace any two of four groups
Channels	Eight
Bit Depth	24 bit

General Specifications

Power Consumption	10 watts
Temperature Range	0 to 40°C ambient (all specs met)
Relative Humidity	0 to 95%, noncondensing
Altitude	0 to 10,000 ft

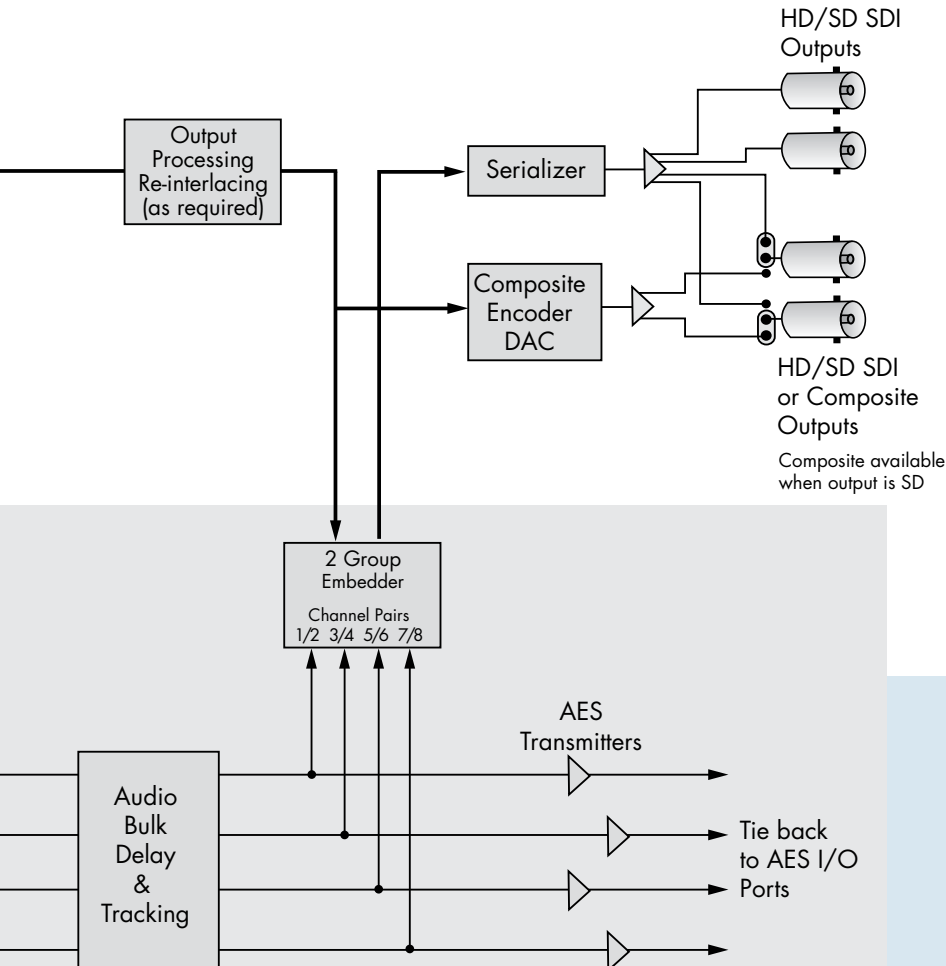

8415 8 Channel Audio Processing Option